

Research paper

Quantification of airborne noise emitted by ships based on class notation

Marco Biot^a, Davide Borelli^b, Tomaso Gaggero^c, Enrico Lembo^d, Luigia Mocerino^{e,*},
Giovanni Rognoni^a, Corrado Schenone^b, Enrico Rizzuto^c, Massimo Viscardi^e

^a University of Trieste, Dept. of Engineering and Architecture, Trieste, Italy

^b University of Genoa, Dept. of Mechanical Engineering-DIME, Genoa, Italy

^c University of Genoa, Dept. of Naval Architecture -DITEN, Genoa, Italy

^d Fincantieri S.p.a, Trieste, Italy

^e University of Naples Federico II, Dept. of Industrial Engineering-DII, Naples, Italy

ABSTRACT

In addition to a number of other forms of environmental impact by shipping activities, airborne noise radiated by ships, too, has come to the attention of Regulatory Bodies in the latest years. The presence of strong acoustic sources on board, and the proximity of the port to inhabited zones represent the main technical aspect of the problem. To meet the demand for control of the airborne noise radiated by a ship, in 2019, the Lloyd's Register issued a class notation on airborne noise emissions by ships, setting a procedure for awarding this notation. Numerical models for the prediction of airborne noise propagation represents a favorable element for the evaluation and control of the airborne acoustical impact. This paper reports the application of this additional class notation and its effectiveness in characterizing the noise field radiated by a cruise ship. The performances of different software in terms of the reproduction of the noise field radiated by a ship and with specific reference to the predicted levels at normative reference distances have been carried out. Results shows the potentiality of this type of approach and first interesting conclusions as regard the radiated airborne noise from a large cruise ship.

1. Introduction

According to the United Nations maritime transport (United Nations, 2019), in 2018 almost 12 billion tons were moved by commercial ships on international routes (+2.7% of traffic compared to 2017, pre-COVID data, see Fredianelli et al., 2020) reaching a share of more than 85% of the total world transport of goods. Ship transportation is by far the greenest mode for moving goods and people (Fredianelli et al., 2020) but, nevertheless, due to the volume of traffic, it is responsible for a considerable share of environmental pollution, considering both global and local effects (Mocerino et al., 2022).

Although maritime transportation would not exist without large ports representing focal points of the logistic chain devoted to the transportation of goods and passengers all over the world, unfortunately, the operations carried out in ports are quite intrusive in terms of environmental impact, in particular as regards noxious compounds in exhaust gases and noise emissions.

The environmental impact of ships has been, on the other hand, controlled and reduced in a number of aspects in the last decades (de Lorenzo et al., 2010). The subject has been constantly present in the agenda of the International Maritime Organization (IMO) and particularly of its Marine Environment Pollution Committee (MEPC). As

known, the key IMO Convention on the subject is the MARPOL (MARine PoLLution- International Convention for the Prevention of Pollution from Ships) first issued in 1973, modified by Protocols in 1978 and 1997, and updated with amendments throughout the years. The focus of the MARPOL is the protection of the marine environment from solid, liquid, and gaseous polluting compounds released by ships during operation or because of accidents. Other elements of the IMO environmental policy are the International Convention on the Control of Harmful Anti-fouling Systems on Ships (IMO, 2001) and the International Convention for the Control and Management of Ships' Ballast Water and Sediments (IMO, 2004) respectively covering the toxic release by hull anti-fouling paints and the biological pollution generated by the diffusion of exogenous species carried by ships in the ballast water. The Hong Kong International Convention for the Safe and Environmentally Sound Recycling of Ships (IMO, 2009) regulates the scrapping of old vessels.

The above short summary shows the effort produced by the top Regulatory Body for shipping (IMO) to reduce the environmental impact of sea transportation. So far, the focus as regards the operational emissions has been on the release of noxious compounds with effects on the local environment (in the proximity of the ship: emissions of NO_x, SO_x, and particulate Matter (PM) from internal combustion engines) and on a

* Corresponding author.

E-mail address: luigia.mocerino@unina.it (L. Mocerino).

<https://doi.org/10.1016/j.oceaneng.2024.117085>

Received 31 July 2023; Received in revised form 1 February 2024; Accepted 6 February 2024

Available online 10 February 2024

0029-8018/© 2024 The Authors. Published by Elsevier Ltd. This is an open access article under the CC BY license (<http://creativecommons.org/licenses/by/4.0/>).

global scale (Green House Gases and Ozone-Depletion emissions, again mainly, but not only, from IC engines), with due emphasis on the life cycle of vessels.

In addition to the aspect of the chemical/biological releases in the environment, attention has been captured recently by other forms of pollution related to the release of energy in the environment (ABS, 2021; Badino et al., 2016; Coppola et al., 2019; IMO, 2014). In other fields, examples of this type of pollution can be found in the thermal energy released by the cooling system of large power plants or in the electromagnetic waves emitted by powerful telecommunication systems. Noise, in particular, can be categorized as a form of energy emission affecting the local environment around the source. Over the last decade, acoustic aspects have become of great interest in several engineering fields, like urban planning, the design of dwellings and industrial plants, and vehicle engineering.

Coming to ships, in the past, airborne noise on board vessels has generally been regulated in living and working spaces to the advantage of passengers and crew. Recently (Badino et al., 2012a), the external acoustical impact of ships on third parties has been taken into consideration, too, both concerning underwater propagation, (affecting the marine fauna), and airborne noise, (affecting the terrestrial fauna: humans, in particular). The airborne noise related to shipping activities affects in particular the population living near ports or close to straits and navigation channels (Coppola et al., 2018).

Particularly in the Mediterranean Sea, (but not only there), ports have developed in major sea cities, with densely inhabited areas close to the quays. This explains the attention that Regulatory Bodies have started to devote to the issue of airborne noise radiated from ships, often following complaints from the population affected by this type of emissions. In addition, many studies demonstrate that prolonged noise exposure can generate several alterations and diseases such as cardiovascular or respiratory disease, hypertension, and sleep disturbance (Attenborough and Van Renterghem, 2021).

In 2008, Di Bella et al., 2008 realized an acoustical characterization and a map of the noise emitted from four kinds of passenger ships (inland navigation ships, ferries, large and small cruises) in the port of Venice. The geometrical and acoustical model of the port was developed in the SoundPlan environment according to Directive, 2002/49/EC. Curcuruto et al. (2015) carried out a survey of the noise due by moored passenger ships in the Civitavecchia port area. The measured sound levels were analysed in terms of both frequency spectrum and overall noise levels, also taking into account the effect of various sources aboard the ships.

According to Weyna (2021), several promising programs have been realized employing finite-element, statistical-energy, or boundary-element analysis to predict airborne and structure-borne noise generated by ship sources.

In Badino et al. (2012b) to test the reliability of current commercial simulators in predicting the noise field from complex sources (such as ships), the airborne noise propagation from two different vessels has been modelled; the obtained results raised a few questions about the characterization of noise sources (in terms of typologies and magnitude) and ship surface within this commercial software.

Di Bella and Remigi (2013) proposed an evaluation method for characterizing ship noise sources, consisting in a retrofit procedure based on formulas described in the ISO 9613-2 standard, and comparing measured and calculated sound pressure levels at receivers chosen according to the requirements of the UNI 11443-1 standard.

In 2019 Bernardini et al., 2019 presented an acoustical characterization of several small vessels at different speeds in port, using short- and long-term measurements. Results were used to generate a map of noise caused by vessels moving in Livorno's canals with simulations validated using long-term measurement. In Coppola et al. (2018) on-board and on-site in-port measurements of the ferries berthed in the port of Naples have been carried out; a geometrical 3D model was created, including all bodies present in the acoustic field of the

surrounding area (mooring zones and buildings in addition to the ferry ship); finally, post-processing checked the consistency between the actual acoustic field and numerical model results. In Vukić et al. (2022) three objectives are pursued: the identification of noise sources in the port area, an overview of strategic noise maps and simulations of noise propagation from ships at berth, and the calculation of external costs of noise pollution. Schiavoni et al. (2022) summarize the recent results of research regarding port noise sources to provide a comprehensive database of sources that can be easily used, among other things, as input to the noise mapping phase. A few projects and studies have been carried out on the characterization of port sources and the acoustic mapping of harbors (Alsina-Pagès et al., 2019; EcoPort Project, 2011, 2020; Herramienta Automática de Diagnóstico Ambiental, 2005; NoMEPorts, 2008; Schenone et al., 2016; SIMPYC, 2008). Projects addressing airborne noise from berthed ships have been carried out in recent years. One of the most recent ones is the Noise Exploration Program To Understand Noise Emitted by seagoing ships (Neptunes Project,) project initiated by several ports in Europe and the rest of the world to provide "tools to support a sustainable port development by reducing nuisance related to seagoing ships". The principal results of the project have been a Measurement Protocol and a Best Practice Guide describing effective measures, including "noise awareness methods". Another reference project was the EU project SILENV which covered onboard, underwater, and external airborne noise and developed a measurement protocol for airborne external noise from ships (SILENV, 2012). Another relevant fact is the decision by the World Port Sustainability Program (WPSP) to include airborne noise in the Environmental Ship Index (ESI) formula as of 2020, allowing for a possible reduction of port dues for quiet vessels (ESI Project, 2011).

This paper presents several innovations compared to the state of the art: application of the new class notation on a real cruise ship with thousands external noise sources on board, database of on-board noise sources catalogued and characterized one by one, use of three different commercial software to test their strengths and weaknesses, and cross comparisons to test the consistency of the results obtained and ISO checks.

The overall external airborne noise emission from a ship is due to several single sources acting on the ship's surface. The main categories of external sources include (Borelli et al., 2016):

- a) Funnels (as ending points of exhaust gas ducts)
- b) Ventilation inlets and outlets (ending point of the ventilation systems of any technical space, including machinery room)
- c) air conditioning inlets and outlets (ending points of HVAC systems, mainly in living spaces)
- d) external sources directly radiating outside (e.g., winches and other handling equipment for cables, anchors, and chains). They generally may be neglected in most operating conditions of interest.

As mentioned, these sources need to be identified in terms of position on the external surface of the ship and sound power (depending on operating conditions).

In this work, the noise source is represented by a large number of independent point sources placed on a complex and large surface (cruise ship) in slow motion (at least if compared with other vehicles). The transmission path, on the contrary, is relatively simple, being made of a half-space of a homogeneous medium (air), bounded from below by a (comparatively) flat and reflective surface (sea surface).

It should be clarified that the example presented was intended to show a methodology for approaching the problem of acoustic emissions from ship in port, rather than provide an in-depth case study. In particular, the results presented focused on the first steps for approaching the application of class notation, with the purpose of providing an overview of the necessary initial activities and starting data.

The paper has been structured as follows: after this introduction, the

regulatory framework and the airborne noise class notation will be exposed in Section 2. To follow, Section 3 describes the principal methodologies applied: the propagation software used, the noise sources data collection, the model generation, and the procedure for positioning the receivers. Section 4 exposes the first results obtained from the case study, Section 5 a coherence check, and finally Section 6 reports a discussion and conclusion part.

2. Regulatory framework for the control of airborne radiated noise by ships in ports

As mentioned above, other forms of the environmental impact of ships at sea are definitely under the control of IMO regulations: once the approval process of such regulations is completed, rules and requirements issued by this United Nations Agency are homogeneously applied by Member States around the world. Differently, the control of the effects of noise emissions from ships at specific ports is within the sphere of influence of several National and Local Authorities. Coast Guard, Port Authority, Health Care Agency, and Municipality are among the Authorities which may be involved in the normative effort on the subject, making it quite difficult to obtain a coherent normative framework. Even though the European Union passed the European Noise Directive, 2002/49/EC (E.U. 2002), requiring member states to produce strategic noise maps and action plans for roads, railways, airports, and urban centers every five years, ports are excluded from these general requirements.

Probably, it has been right the dispersion of responsibilities on the subject that has prevented so far to build an international framework of Airborne Noise requirements for ships, even though progress in tools for acoustics, acoustical modelling techniques and noise countermeasures has made the sector mature for regulation. The first sign of an inversion in the trend has been in the last years the issue by different Classification Societies: DNV-GL, Lloyd's Register, RINA, and ABS of voluntary class notations on airborne noise radiated by ships in port. The class notations have not yet produced any mandatory normative action but started a process that most probably will have in a short time that outcome. Although in this study, the Lloyds' Register notation developed by is used in detail (as it has been the first issued), all the notations will be first exposed and recalled in order to highlight the different features.

With the "ABS Guide for the Classification Notation Underwater Noise and External Airborne Noise", ABS in 2022, introduces two maximum allowable external airborne noise limits that can be applied to all types of vessels:

- AIRN for the vessel that has met the external airborne noise criteria specified in this Guide as confirmed by measurement.
- AIRN + for the vessel that has met the more stringent external airborne noise criteria specified in this Guide as confirmed by measurement.

AIRN-M (a, b) for the vessel that had its external airborne noise measured by the measurement procedure: a denotes the averaged A-weighted external airborne noise level, between 31.5 Hz and 8000 Hz, of the vessel under normal berth condition, in dB(A) and b denotes the averaged A-weighted external airborne noise level of the vessel in low-frequency range, 31.5 Hz–160 Hz, under normal berth condition, in dB (A).

The principal machinery and systems that are to be switched on during the measurement are auxiliary engines, engine room and accommodation ventilation, cargo cranes and cargo ventilation fans, reefers (for container ships), and pumps on deck (for tankers). The maximum allowable external airborne noise limits at 100 m away from the vessel for the AIRN and AIRN + notations are 50 dB and 45 dB respectively for the entire frequency range (31.5–8000 Hz) and 45 dB and 40 dB respectively for the low-frequency range. The microphone is to be at a height of at least 3.5 m above the water surface. The notation

offers two different post-processing steps for background noise correction and distance correction.

The RINA (Part F, Cap.6, Sez 4) notations NOISE-PORT-OUT(X) and NOISE-PORTIN(X) are assigned when noise measurements are carried out in the port area outboard and inboard respectively, and only if at least merit level 1 is reached (at 100 m). The notations are completed by a number (1–100) which represents the merit level achieved for the assignment of the notations where 100 corresponds to the lowest level of noise. The external noise limit at 100 m is min 45 and max 65 dB (A).

The new voluntary class notation, developed by DNV, known as "Quiet", addresses the vessel's external airborne noise emission in port (DNV QUIET, 2019). All types of vessels built in compliance with the requirements may be assigned the class notation "Quiet". The external noise levels shall be measured in a port or another suitable site approved by the Society. The notation specifies four important parameters related to external airborne noise for the Idle (I) or Working (W) operating conditions: the most important is L_s (L_p), the *maximum A-weighted sound pressure level at a distance of 100 m on the starboard (port) side of the vessel*. As an alternative, all important noise sources on board the ship can be measured, and the sound pressure level at a distance of 100 m from the starboard side is calculated. The resulting levels are rounded up to the closest even value. Two different measurement procedures are available: far-field measurements or individual source measurements. The former one consists of sound pressure measurements along each side of the vessel; the latter one consists of a source-level measurement of the most important noise sources on board combined within a model to calculate the relevant sound pressure levels. The outcome of both procedures is the maximum sound pressure levels at a distance of 100 m on each side of the vessel. All equipment and systems shall be running at their normal mode for the operation chosen.

The new class notation called "Procedure for the Determination of Airborne Noise Emissions from Marine Vessels" includes criteria for the assessment and a procedure for awarding the notation (Lloyds' Register, 2019). The notation applies to new or existing self-propelled ships of length greater or equal to 24 m and may be awarded when the measured values fulfil the defined criteria. The application procedure identifies two main operating conditions: harbour moored and free sailing. In the former condition, the ship is moored at the pier with all equipment normally operating at the harbour (including in case electric power supplied from shore) and with the main propulsion system turned off. For ships with garages such as passenger ferries and ro-ro cargo/passenger ships, the car deck ventilation shall be included, while the noise directly emitted from cars/trucks and passengers during loading and unloading operations is excluded from evaluation. The free sailing condition corresponds to the ship moving at reduced speed inside port areas or along the coast or channels, with the whole equipment normally operating during the navigation (main and auxiliary engines, and ventilation systems in operation); the standard sailing speed is 5 knots. The assessment is to be carried out at least in the frequency range 31.5–8000 Hz in 1/1-octave bands.

The adopted indicators are:

- $L_{WA, ship}$ (*Ship Sound Power Level*) as the energy sum of all single-source sound power levels for a given operating condition;
- $L_{Aeq,T}$ as the *Equivalent Continuous A-Weighted Sound Pressure Level*;
- $L_{pAS,max}$ as the *maximum A-Weighted root-mean-square sound pressure level* measured with acquisition constant SLOW during the passage of the ship or the defined operating condition, according to IEC 61672-1;
- d is the *distance to the side in the horizontal direction*.

Table 1 shows the limit values for the assessment criteria (Lloyds' Register, 2019).

To obtain the ABN notation at the various levels reported in column 1 of Table 1, the ship shall meet all four requirements at the same level (same row of Table 1), i.e. the ABN(*) notation at a given level may be

Table 1
Assessment criteria.

Sound power	Harbour moored		Free sailing		Distance to ship side
	(dB)		(dB)		(m)
	$L_{WA,ship}$	$L_{Aeq,T}$	$L_{WA,ship}$	$L_{pAS,max}$	d
Super Quiet (SQ)	82	40	92	50	50
Quiet (Q)	88	40	98	50	100
Standard (S)	96	40	106	50	250
Inland waterways (IW)	101	65	111	75	25
Commercial (C)	108	40	–	–	1000

awarded only if the airborne noise levels measured are less than the corresponding limits. The ranking of a vessel requires therefore the correct evaluation of two different quantities (Lloyds 'Register, 2019.

- the ship sound power levels, $L_{WA,ship}$, intended as the energy-based sum of all single-source sound power levels. To determine the single source power levels of each source onboard the standards to be followed are ISO3744 or ISO9614;
- the sound pressure level (in terms of $L_{Aeq,T}$ and $L_{pAS,max}$) measured at specific distances from the vessel.

In a design phase, it is therefore recommended to realize a 3D calculation model of the ship according to ISO 9613-2. This model shall include the main geometry of the ship and individual noise sources on the surface of the vessel, as well as screening, reflection, and absorption effects by the ship structure, to make possible through the model to identify the specific SPL values at given target points in the far field. Following this procedure, each source shall be characterized by its sound power level and, if relevant, a directivity index.

In the prediction model, main sources are considered the exhaust stacks and funnels of main and auxiliary engines, the ventilation air intakes and outlets, all the external fans, any special equipment in operation (such as cranes and/or cargo pumps), and, if relevant, the hull radiated noise. The calculated noise emitted from the exhaust funnel shall also include, if present: silencers, scrubbers, and filters. The requirement prescribes, in addition, the way for modelling the various external sources on board: small ventilation openings and exhaust stack openings may be in general be modelled as point sources, while larger ventilation grids shall be modelled as surface sources.

The design stage calculation report shall include primarily: the selected assessment criteria in each operating condition, all user input according to ISO 9613 (ISO 9613-1, 1993; ISO 9613-2, 1996), the single source sound power levels, the determined ship sound power levels, any deviation from the calculation method, and a calculated sound pressure levels as color-coded noise contour maps.

On-site measured levels for the verification of compliance with the class notation should be carried out. For both of the two pre-set operating conditions, the notation mentions on-site measurements following preferably a "near-field" method (limited to a distance from the source equal to about a wavelength of sound or equal to three times the largest dimension of the sound source). The weather conditions for carrying out measurements should not exceed 3 on the Beaufort scale and a sea state 2, according to World Meteorological Organization (WMO) sea state code. The ship under test should be ballasted to the design draught with all equipment, normally in operation, actually running. The sound pressure levels $L_{Aeq,T}$ and the $L_{pAS,max}$ shall be determined by updating the 3D calculation model with the single-source sound power levels and verifying at a relevant distance and at least two heights (3.5m and at ship height above sea level) the compliance to the assessment criteria.

In the following, the main problems met and approaches followed in modelling the entire ship and her noise propagation field are analysed.

The three elements needed for a proper simulation are taken into account: noise sources characterization; noise propagation and receivers' location.

3. Methodology

A necessary pre-processing for setting up a realistic acoustic model of a ship is the generation of an inventory of noise sources on board. The main issue is represented by the number of different external sources that, for a large cruise vessel, may reach hundreds of items. In practice, each air intake and outlet grid is to be considered an external acoustical source. Each of such sources is to be identified in terms of position on the ship surface and functional relation with the various machinery elements that may be active and radiating outside the ship through that position.

In a few cases, more internal sources convey ventilation air in the same duct with a single output point. The opposite case of multiple outlet grids at the end of the same outlet/intake duct is possible, too. The airborne noise emitted by a ship depends on the various operations carried out by the vessel, each requiring to run different plants and systems on board. In addition, the same plant can be run in different conditions, with different acoustical emissions.

For these reasons, the results of acoustical surveys may be affected by large uncertainties if the operating condition of every single plant is not controlled (Fredianelli et al., 2020). In every ship operating condition, a detailed description in terms of at least the power percentage of each running machinery is needed. The sound power radiated, in fact, can, in a first approximation, be considered proportional to the power delivered by the machinery.

3.1. Propagation software

The ISO Standard 9613-2 (1), is a simple and practical empirical method to calculate outdoor propagation of sound from a point source to a receiver. Later, ISO 9613-2 was implemented in various ray-tracing software packages to make larger, more sophisticated, and more accurate models possible (Brittain, 2009). Other methods dealing with outdoor sound propagation, such as VDI, 1988 (1998), CONCAWE (1981), Nord2000 et al. (2002), and Nota et al. (2005), among others, are considered more advanced calculation methods, since they apply more sophisticated propagation models/algorithms based on physics, which give acceptable runtimes for engineering applications (Brittain, 2004; Brittain and Hale, 2008). All these methods can be described as 2.5 dimensional (more than 2, but less than a full 3 dimensional), as the calculation is carried out for each plane containing a ray between a source and a receiver. Despite the empirical approach of the ISO 9613-2 standard (and other similar methods of the same period), it can be considered a true innovation in acoustical engineering, since it contains the essence of outdoor sound propagation, and it offers engineers the possibilities of calculating complicated scenarios in a relatively simply spreadsheet format.

The availability of faster computers has largely contributed to the development of more sophisticated and accurate algorithms that have been implemented in modern simulation software, very often characterized by a user-friendly interface, allowing use also to users having limited knowledge of sophisticated mathematics and physical concepts. In this work, three software have been used and compared in order to highlight advantages and disadvantages: Soundplan, MithraSIG, and OTL-Terrain:

- **SoundPLAN** is a noise modeling software used since 1986 with main applications on prediction, assessment, and mapping of environmental noise and indoor noise modeling. Some of its uses include noise mapping of speed and road surface for a road or the selection of height and absorption coefficient of a noise barrier. SoundPLAN noise also includes new standards CNOSSOS-EU (roads, railways,

industry, and aircraft noise). The software supports and complies with changes that have been proposed to [ISO/TR 17534-3:2015](#), which relates to acoustics software for the calculation of sound outdoors. Additional recommendations have been proposed for the calculation method of ISO 9613-2, which have been also implemented in this application; the Sound PLAN' developers have been a member of the working group that has helped develop these new measures.

- **MithraSIG** uses powerful algorithms based on asymptotic methods, such as ray propagation and adaptive beam propagation. These algorithms are equally suitable for prediction in an enclosed environment, in an open environment with vast spaces, and in non-flat areas where the terrain topography affects propagation. The physical simulation engine computes noise propagation according to the requirements of current regulations, including European [Directive, 2002/49/CE](#), which takes into account the effect of meteorological conditions. The geometric engine range from rapid ray propagation to beam propagation enabling diffraction on the vertical edges of objects. Calculation methods included are CNOSSOS-EU, NMPB2008 (octave and 1/3 octave), ISO9613, NMPB96 (XP S31-133), and Harmonoise (octave and 1/3 octave).
- **OTL-Terrain** is a software application that simulates and predicts sound propagation from a source to a receiver using wave-based geometrical acoustics. It utilizes image source sound ray modelling in a proper 3D space that solves Helmholtz's sound wave equation and thus calculates wave phenomena such as phase changes upon reflection due to finite reflector size and impedance, edge diffraction effects, and turbulence ([PEMARD](#)). [Lam \(2005\)](#) demonstrates that three-dimensional spherical wave sound propagation, as implemented by wave-based geometrical acoustics, provides as accurate results as the Boundary Element Method (BEM) in room acoustics. The OTL-Terrain engine is based on a general geometrical acoustics ray model based on analytical solutions for various wave phenomena and can simulate sound propagation in arbitrary geometries. It also includes the 9613-2 calculation method as an option for those who need to comply with regulations and for comparison purposes and the Sound Path Explorer (SPE), an algorithm developed in-house to detect valid diffraction and reflection sound paths from source to the receiver in a proper 3D, and based on the image-source method and the geometrical theory of diffraction ([Economou and Peppin, 2012](#); [Keller, 1962](#)).

3.2. Noise sources, characterizations, and data collections

For each running piece of machinery in running conditions, the airborne noise external radiation depends on the levels at the source and on the transmission paths connecting the source itself and the position where the noise reaches the external atmosphere.

In principle, some of these transmission paths include structure-borne portions, where part of the mechanical energy emitted by the source takes the form of transversal waves in solids (ship structures), and is converted into airborne noise when it finally reaches the outer surface of the ship. Conversions from structure-borne to airborne noise (and possibly vice-versa) are however not very efficient. The most effective transmission paths for airborne noise towards the exterior of the vessel are those along which a fluid continuity occurs between the source and the external atmosphere. In this case, acoustic energy is carried by longitudinal (compression/rarefaction) waves within the fluid itself. When the wave, possibly conveyed by ducts, reaches the external atmosphere, the transmission goes on as free-field external propagation (which is the subject of this work).

What above suggests that, when dealing with external noise radiation, all the openings through which a continuous fluid connection between an internal source and the external air is realized need to be considered and characterized as external noise sources.

Quantification of the external emissions can be pursued through

prediction or experimental methods. A prediction can be obtained by evaluating the machinery noise strength at the source (on the surface of the piece of machinery) and the effect of the transmission ducts (including, if applicable, the contributions due to fans or silencers placed along the path).

The noise levels related to the exhaust gas duct of the funnel are generally provided by the manufacturer at least for the 100% MCR operating condition of the engine. These information may include sound power levels after the turbocharger, data about the silencer, and the attenuation of the duct. In the case of ventilation and air conditioning outlets, the external source strength is related to the noise possibly present in the space treated by the plant (including compressors of the Air Conditioning system, if applicable), increased by the effects of fans and decreased by the attenuation of ducts, plenum and, in case, silencers. A different strategy is to characterize experimentally the external source by measuring the sound power levels directly at the inlet/outlet grid on the outer surface of the ship. While predictive procedures take advantage of global knowledge of the plant, an experimental characterization avoids the uncertainties connected with predictions and provides a sound basis for the external propagation study. A campaign for an effective source characterization, however, is to be carried out by a careful application of protocols in terms of measurements and data recording procedures, to generate reliable results. Each measurement should be carried out in the proximity of any external grid source at a controlled distance and angle, with the machinery operating in a controlled condition.

Prediction models have the obvious advantage of being applicable in a design phase.

3.3. Model generation

In order to build a model for the airborne noise emission from the ship, first a ship geometric model is needed. Being the analysis focussed on the acoustic field radiated outside the ship, only the outer surfaces of the emitting body are used to define the model. In particular, the ship body model is a continuous surface enveloping all the closed volumes of hull and superstructures, with special attention to the funnel. In the generation of the geometrical model, a suitable balance should be found between accuracy in the resulting noise free-field and time devoted to pre-processing and computation. The main acoustic effect of the enveloping surface is the reflection of the noise field into the surrounding environment. Accordingly, sound reflection characteristics need to be set for the ship's external surface.

The second step in the model generation is to place the various external sources of ABN on the ship's surface, each characterized in terms of power. As mentioned, such sources correspond to intakes and outlets of the ventilation and air conditioning systems and the exhaust gases outlet of the main engines. It is not excluded that noise sources can be also placed outside the enveloping surface, as in the case of pipe terminals extending over the top of the funnel.

In the numerical model, as a third element the external environment, needs to be represented, too. This is generally accomplished by creating a horizontal fully reflecting plane extending around the ship, modelling the sea surface in still water. Free field conditions are those included in the assessment from the Classification Societies, which are focussed on ship emissions, independently from the influence of specific environmental conditions. The simplest boundary condition is therefore an unbounded plane representing a flat sea surface all around the ship. This is the case treated in the present analysis.

If the purpose of the model is to assess the acoustic impact of the ship in a specific environment (harbour, channel, or other) the natural or anthropic elements of the surfaces surrounding the ship need to be modelled (ground orography and or geometry of the buildings), as well as their acoustic properties. In some cases, the environment is to be characterized also in terms of meteorological conditions (wind, rain, snow)

Historically, commercial software for acoustic propagation models has been developed to evaluate the impact on residential areas of noise emissions from industrial plants, roads, railways, and airports. Consequently, they are focused on the modelling of buildings representing the typical element for the emitting body or the surrounding environment for the civil and industrial sectors: so far specific features are not implemented for modelling complex bodies like a ship, characterized by an outer double-curved surface. An exception is represented by the MithraSIG software where a specific module for ship noise has been implemented. The module is very simple and cannot be directly used for the models requested by the Classification Societies procedures, but it is a good basis to include the ship in the sources to obtain a complete city sound map.

First of all, taking into consideration that the positions where the noise field should be evaluated are far away from the ship, the ship's outer surface can be modelled with some approximations. In particular, small protrusions on the outer surface not affecting the far field noise can be neglected in the body model: this is the case e.g. of bulwarks and obstacles caused by deck outfitting. These limited-size obstacles to propagation should be modelled only when a near-field characterization is requested. The same applies for example to lifeboats placed along the shipside and superstructure in front of noise sources like air intakes or outlets. All the openings provided with permanent closures are to be considered as part of the envelope surface; this applies to all windows and portholes, and also to the doors giving access to balconies and open decks. Special consideration is to be given to large indentations of the envelope surface of the ship where noise sources are placed. Other appendages that need to be modelled, are balconies, bridge wings, and any similar structure capable of reflecting the acoustic field in such a way as to modify its level at a distance.

Finally, particular attention must be paid to the funnel: when it is made by a continuous plating it should be modelled as part of the ship however, in some cases, the funnel is characterized by a grid structure and so it can be considered acoustically transparent. The noise source should be placed in correspondence to the terminal point of exhaust pipes (wherever such point is in respect to the funnel structure).

The generation of the numerical model is based on the technical sheet made available by the ship designer. The best starting point for modelling the envelope surface of the ship body is given by the drawings of the ship's general arrangement. Even if available in a CAD format they cannot be directly imported in the noise field prediction software because of the excessive level of details of such drawings. Following what is above reported, these drawings need to be suitably simplified. Depending on the capabilities of the software used, another kind of surface input data can be taken as a starting point for the modelling, (e.g. surface meshes created for Finite Element method calculations).

Summing up all the considerations on the model discretization made above, the operating procedure starts from the subdivision of the ship body in several horizontal stripes each of them extending f.i. between two consecutive decks. The next step, for each selected strip, is the vertical extrusion of the deck outer perimeter to create the approximate surface of the ship body. Finally, by fixing the only physical parameter describing the surfaces, the sound reflection can be set to 100% for both the ship body and the sea.

3.4. Positioning of receivers

As above mentioned, the acoustical scheme of a ship is made by several sources placed on the geometrical model of the outer surface of the vessel. Depending on the ship type, the model can be very complex with a significant number of sources of different kinds: point, surface, etc. For a modern cruise ship, the total number of sources can easily be higher than a hundred. For these reasons, a check for the internal model coherence is needed to avoid possible mistakes in input. A way to carry out such a check is to verify that the total acoustic power of the ship is equal to the sum of the single acoustic powers of the sources used in

input to the model. Different procedures can be used, but it is here suggested to apply to the numerical model two ISO standards aimed at assessing the acoustic power of complex sources given a series of measures of acoustic pressure at specific points. In particular, for this specific case of ships, ISO 8927:1994 and ISO 3744:2010 can be applied. ISO 8927:1994 specifies an engineering method for determining the sound power level of multisource industrial plants by noise pressure levels evaluated in points located in the environment around the plant. The basic assumptions and limitations are: the source radiates substantially uniformly in all directions; the main dimensions are in the horizontal plane and the largest horizontal dimension of the plant area lies between 16 m and approximately 320 m. The procedure suggested is based on measuring the sound pressure level on a closed path (measurement contour) surrounding the plant and determining an appropriate measurement surface as shown in Fig. 1.

The position of the measurement points has to be determined as follows. The average distance between measurement points can be determined by the following equation.

$$\max(0.05 \cdot \sqrt{S_p}; 5m) < \bar{d} < \min(0.5 \cdot \sqrt{S_p}; 35m)$$

Where S_p is the ship surface area as in Fig. 1. As the uncertainties in the method decrease by increasing \bar{d} , it is suggested to take the maximum possible value of \bar{d} . The distance D_m from two adjacent measurement points on the contour should not be greater than $2\bar{d}$. The height of the measurement position must be determined as the average of the heights of all sources present. In the case of ships the funnel, which represents an important source of noise, is typically located at a very different height compared to the other sources. For this reason, the simple average of the source heights can be substituted by a weighted average using the source acoustic power as weight.

This is different from what is prescribed in the ISO standard because the power of each source it is unknown in the experimental procedure but is known when building the numerical model. Once the positions of the measurement points are determined (in the case of numerical models can be called control points), the sound pressure at each point for each frequency must be calculated and the total acoustic power of the ship can be easily determined by following the ISO 8297 procedure. The uncertainty of the method, if the maximum value of d is taken, is for the 95% confidence interval (+ 1.5 dB; + 2 dB).

Another possible approach for the check on the internal coherence of the model is to follow the procedure suggested in ISO 3744:2010. The standard describes methods for determining the sound power level or sound energy level of a noise source from sound pressure levels measured on a surface enveloping the noise source in an environment similar to an acoustic free field near one or more reflecting planes. The procedure is more complex than the one of ISO 8297 but the main advantage is that the hypothesis of omnidirectional source used in 8297 is no more needed. Such assumption can be too strong for some ship types. Initially, a reference box surrounding the source must be identified as shown in Fig. 2. Such a surface must enclose all the significant sound radiating components. A characteristic source dimension is defined as:

$$d_o = \sqrt{(l_1/2)^2 + (l_2/2)^2 + l_3^2}$$

where l_1, l_2, l_3 are the main dimensions of the reference box. The characteristic source dimension is used to determine the extension of the enclosing surface. Its formulation takes into account if the source is placed on one, two or three reflecting surfaces.

In the specific case of ships, only one reflecting surface is present represented by the sea surface and therefore the measurement surface is a parallelepiped (Fig. 2). The distance (d) from the reference box to the measurement surface can be set to any value larger than 1 m. The measurement surface and the number and positions of the measurement points are updated consequently. A good choice could be to use the same

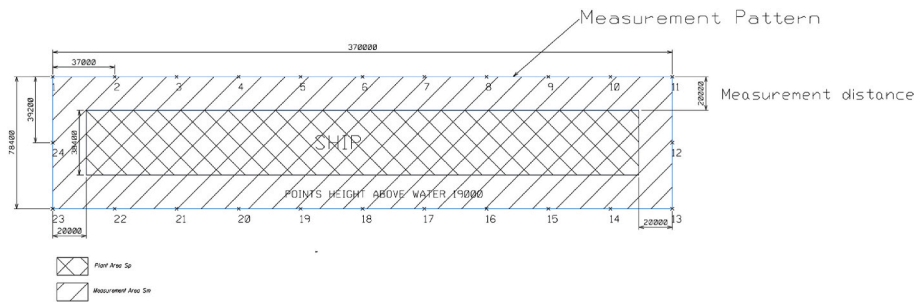

Fig. 1. Arrangement of measurement positions on the measurement contour around the ship (horizontal plane). Measures are in millimetres.

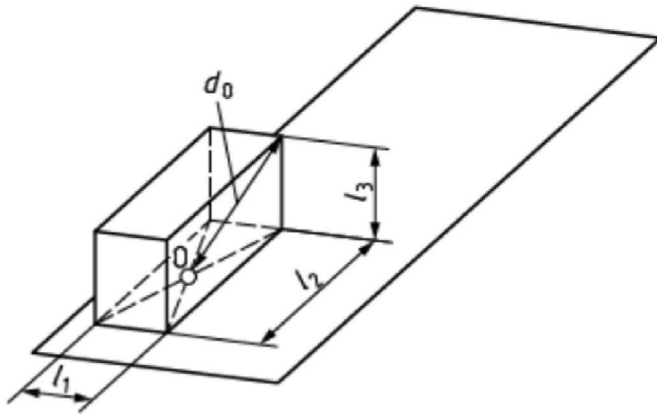

Fig. 2. Reference box on the reflecting plane (from ISO 8927).

distance given by ISO 8297 in order to have a further cross-check among the methods.

The measurement points should be placed considering each of the five planes of the enveloping surface on its own, subdivided so that each plane contains partial areas of equal size with a maximum length of side equal to $3d$. The minimum number of microphone positions is thus 9 for rectangular partial areas or 10 for triangular partial areas. The measurement points used for the specific case are reported in Figs. 3 and 4.

Once the positions for the measurement points are determined, the sound pressure level for each frequency band must be calculated in those points and the total acoustic power is calculated following the procedure described in the standard. The results in terms of the difference between

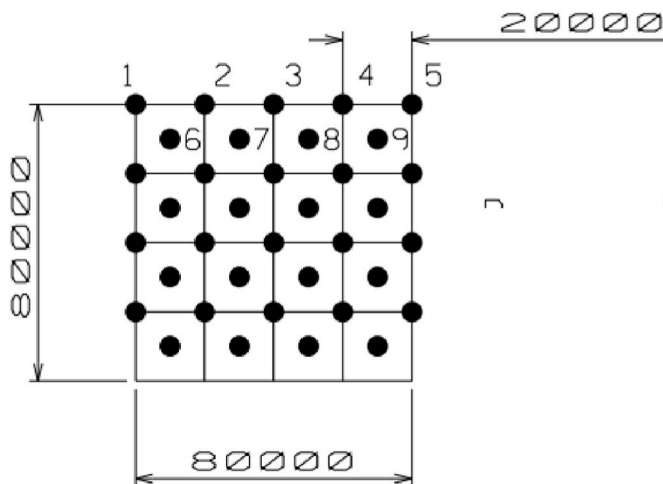

Fig. 3. Bow and stern surfaces. Measures are in millimetres (heights from the baseline).

the ISO value and the input power value (obtained by summing the power of the single sources) are given in Fig. 5 in dB(A) for the results of the simulation.

As it can be noticed from the graph, a good but not perfect agreement can be found between the input total power given to the software, and the total power evaluated following the ISO 8927 and ISO 3744 procedures. Differences are due to both uncertainties in the ISO procedures and model uncertainties. It is interesting to note that no significant improvements have been obtained with the more complex ISO 3744 procedure with much more measurement points. Larger differences can be found at very low frequencies where the model, based on raytracing, shows its limits. In any case, such an internal verification of the model is quite useful as in average it can be reasonably concluded that the power given in input to the model is coherent with the sum of the nominal power of the single sources (and no mistakes have occurred in the input phase).

4. First results

As a further element of evaluation on the pressure field radiated by the ship provided by the software, the acoustic maps of sound pressure in dB obtained on the surfaces at a distance of 50, 100, and 250 m from the hull are reported in Fig. 6. The distances were chosen to be compliant with all the requirements of LR, ABS, and RINA (Lloyds Register, 2019; ABS, 2021; RINA, 2021).

As it can be noted, comparing the highest levels in each map, at 100 m the simulation shows a decrease of at least 9 dB if compared to the map at 50 m; this difference increases to at least 18 dB at 250 m. From the shapes of the noise maps obtained, it is also possible to observe that even in the nearest map to the ship, i.e. the one at 50 m from the vessel, the emission of the ship does not show the presence of single sources, but on the contrary the noise field appears to be diffused along the ship, with an exception for the funnel, showing a stronger signal. This result leads to the conclusion that in the far field, i.e. from 50 m on, the presence of several different noise sources spread on the side of the ship, as well as the presence of smaller scale possible obstacles to propagation such as lifeboats, do not influence the propagated sound field, that can be considered as continuous and spatially homogeneous. The specific effect of the possible obstacle represented by lifeboats hanging along the ship sides (outboard with respect to noise sources) can be seen looking at Fig. 7, where the difference in the acoustical field with or without the presence of lifeboats is represented. The figure shows 0.9 dB as the highest value for the difference at 50 m. The difference between the two radiated fields becomes negligible (0.3 dB) from 100 m on.

5. Simple propagation scheme for the whole ship

In the formulation of any acoustical problem, where the objective is represented by the control/mitigation of the perception of noise by the receiver in a target position, key points are the correct characterizations of the noise source strength and of the transmission loss during the propagation to the receiver.

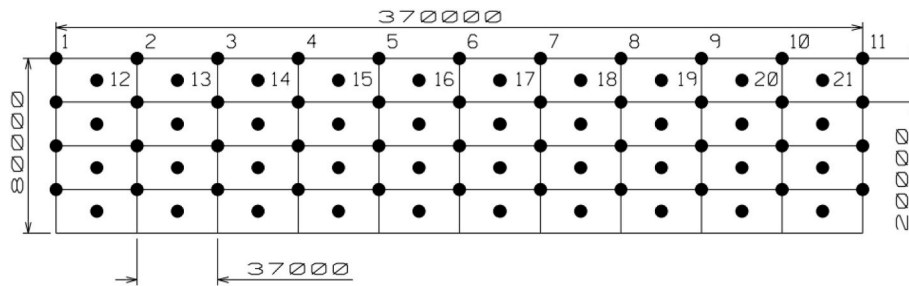

Fig. 4. Port, starboard, and top surfaces. Measures are in millimetres (heights from the baseline).

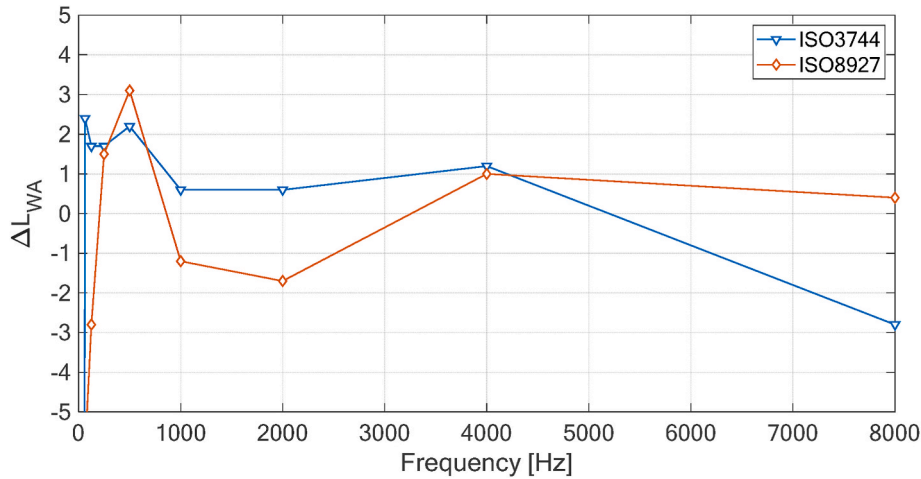

Fig. 5. Comparison between ISO 8927 and ISO 3744 procedure (dB(A)) for the Sound PLAN numerical model.

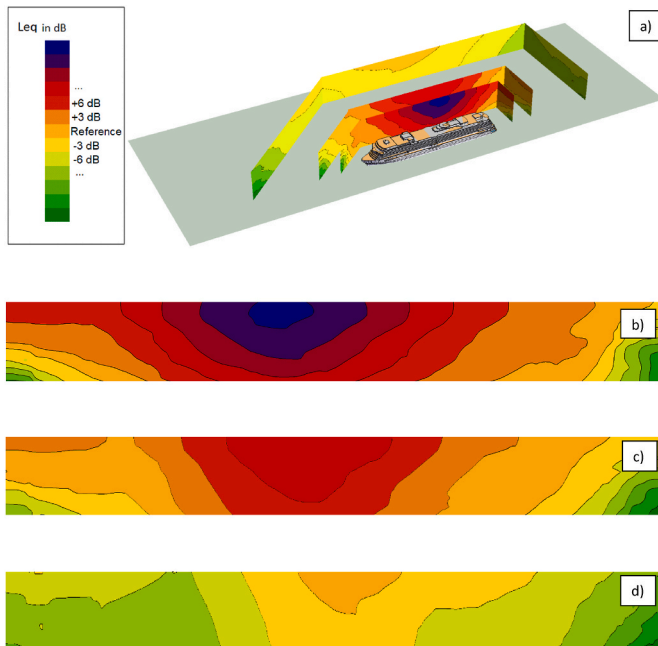

Fig. 6. Vertical representation ($h = 70$ m) of the acoustical field from the ship's hull: a) perspective view; b) at 50 m; c) at 100 m; d) at 250 m (Sound PLAN model).

As regards the second aspect, simple propagation schemes are useful for a quick evaluation of the impact.

A single stationary point source in an unbounded medium would

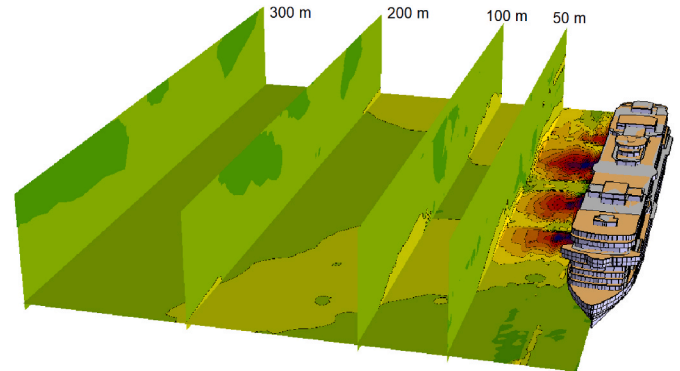

Fig. 7. Perspective view of the difference in the acoustical field from the ship's hull, with and without lifeboats (Sound PLAN model).

have a spherical propagation, producing pressure levels at distance r with a decreasing value according to the known spherical law:

$$Lev(r) = Lev(\text{source}) - 20 \log(r)$$

If the point source is placed on a reflective plane (the ship surface), the propagation can be still modelled with a spherical law, but with higher pressure levels (+3 dB) due to a higher concentration of the same acoustical power in a half space. Local effects can arise due to the local shape of the ship's external surface, which may further concentrate the radiated pressure in limited areas near the single sources. Other possible enhancements in pressure levels may be induced by the reflection from the sea surface, placed in our case below the sources at a vertical distance.

The relationship between the power level of a source and the pres-

sure level at distance r in an infinite space (directivity Q equal to 1) is given by (spherical propagation law):

$$L_p(r) = L_w - [20 \log_{10}(r)] - 11dB$$

The same referred to half space provides

$$L_p(r) = L_w - [20 \log_{10}(r)] - 11dB + 3 dB$$

As regards the source strength, a simpler scheme for the ship is represented by a single point source with an equivalent power.

In the case of incoherent multiple-point sources, the total acoustic power of the ship is split among several incoherent point sources placed along the considerable (but finite) length of the vessel. This situation differs from the simple schemes above reported in that the acoustic power radiated at sources is less uncorrelated in space and in time, even though the total emission is the same.

5.1. Propagation law adopted in the formulation of requirements

In the Lloyd Register Class notation document, requirements are set both at source and at a distance, the former in terms of total radiated power by the ship, the latter in terms of pressure levels at a given distance. These two classes of requirements are logically connected through a hypothesis about the propagation law. In Fig. 8, the various requirements in terms of SPL at various distances (black round dots) are interpreted as points on a straight line of slope -2 in log scale (spherical propagation). The starting point (level at a distance of 1 m) correspond to the pressure level of a point source with the same total power set in the norm as limits for the ship radiating in a semi-infinite (half) space. Accordingly, such pressure level is increased by 3 dB to account for a reflecting plane corresponding to the plane of symmetry of the ship. Such interpretation holds for all the requirements contained in the notation. In other words, the two class of requirements (at a distance and at 1 m) are coherent with each other if the propagation scheme of a point source of equal sound power in a half space is adopted. It should be noted that the requirement is formulated in terms of the maximum level at distances measured from the shipside and not from any point position on board.

As regards the propagation law predicted by the detailed models in the three software environments, Fig. 9 suggests that the spherical law approximates quite well those trends (dots represent the distances at which pressure plots have been predicted).

6. Discussion and conclusions

Requirements and procedures aimed at assessing at a design stage the external airborne noise emitted by ships, beyond the intentions of the proponents, are not always simple and easy to apply and their practical application needs to be tested. In particular, when generating a numerical model for the ship noise source, a first obstacle is found in modelling the external surface of the ship. User interfaces have been

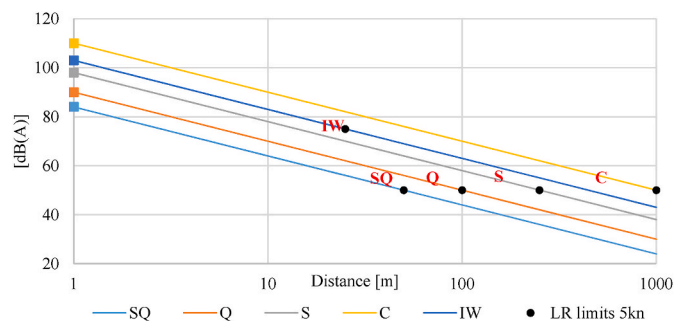

Fig. 8. Interpretation of LR limits in function of the distance. SQ= Super Quiet; Q = Quiet; S= Standard; C=Commercial; IW=Inland Water, see Table 1.

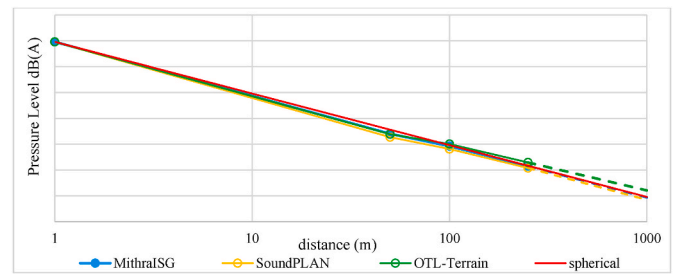

Fig. 9. Simulated noise levels (maximum values on planes at distance d) as a function of the distance.

developed for the geometrical modelling of urban environments: buildings, roads, walls, and terrains are the basic elements available in the software libraries. These elements do not fit with the geometry of a ship, requiring a large adaptation that can generate inaccuracy in acoustic modelling. A second problem arises for the characterization of the external noise sources present on-board in terms of sound power. Few experimental data, lack of reliable databases, and absence of specific correlations make the characterization of the different sources on board (funnel, cranes, auxiliary engines, etc ...) extremely uncertain. The first outcome is an evident need to develop specific measurement techniques to characterize the emissions from the different sources on board.

Given the large number of sources on board, a self-validation method for the numerical model was introduced, based on the idea that the overall sound power must coincide. Therefore, the sound pressure level was calculated for a set of positions arranged on an envelope. Then the total acoustic power was evaluated following the procedures described in ISO 8927 and ISO 3744 standards. This methodology was revealed to be quite effective since a good agreement was found between the overall sound power inserted and calculated through ISO 8927 and ISO 3744 procedures. Despite uncertainties in standard and numerical model implementation, a general coherence was noticed between the power given as input to the model and the overall calculated power resulting from the sum of the single sources. Then the ship numerical modelling was applied to analyze the assessment methods proposed by the Lloyd's Register.

The simulations carried out made evident the lack of relevance of details in the geometric description of the ship surface (decks, balconies, lifeboats, etc.), as well as of the exact positions of the specific sources when predicting pressure levels at distances such those settled in the analysed requirements. Finally, attention must be paid to the assumption of an isotropic point source for the sound sources on board. This hypothesis, accompanied by those of free field propagation, constitutes a critical element affecting the model's accuracy. LR regulation provides measures at different distances depending on ship category, DNV adopts 50 m for all types of ships, Rina and ABS recommend 100 m. The first results, reported in Section 4 of this work, then verified, in Section 5, in their consistency with the previously introduced hypotheses, constitute the basis for future applications and give a first snapshot of the potential of this type of simulations. To conclude, it is really valuable that the ship classification societies are introducing methods for assessing the outdoor airborne noise of ships, on the other hand, the application in the field of the proposed evaluation techniques rises some critical issues. For the assessment of the outdoor noise impact of ships to come out of a pioneering phase and to the aim of defining accurate and shared evaluation methods, work is therefore still needed by both regulatory bodies and research organizations. Field-testing of the proposed methods, evaluating the accuracy of current measurement techniques, validating the replicability of the results, and testing the consistency between numerical modelling and experimental tests are all challenges to the scientific community, and the maritime industry is called to respond. As future developments, to better support the validity of the analysis and to show

the applicability and advantages of our approach, the authors will strive to obtain permission of publishing more detailed data and comparisons with results on full-scale models, (maybe in an aggregate mode, for industrial confidentiality reasons).

CRedit authorship contribution statement

Marco Biot: Writing – review & editing, Software, Methodology. **Davide Borelli:** Writing – original draft, Software, Investigation. **Tomaso Gaggero:** Writing – original draft, Software, Investigation. **Enrico Lembo:** Resources, Funding acquisition. **Luigia Mocerino:** Writing – review & editing, Writing – original draft, Software, Investigation, Data curation. **Giovanni Rognoni:** Writing – original draft, Methodology, Formal analysis. **Corrado Schenone:** Writing – review & editing, Supervision, Methodology. **Enrico Rizzuto:** Writing – review & editing, Project administration, Conceptualization. **Massimo Viscardi:** Writing – review & editing, Validation, Software.

Declaration of competing interest

The authors declare that they have no known competing financial interests or personal relationships that could have appeared to influence the work reported in this paper.

Data availability

The data that has been used is confidential.

References

- ABS, 2021. GUIDE for the CLASSIFICATION NOTATION: Underwater Noise and External Airborne Noise. American Bureau of Shipping, Spring (TX), 2021.
- Alsina-Pagès, R.M., Socor, J.C., Bergadà, P., 2019. The impact of man-made noise on the passenger transport stations of Port of Barcelona. INTER-NOISE and NOISE-CON Congress and Conference Proceedings 259 (3), 6912–6922. Institute of Noise Control Engineering.
- Attenborough, K., Van Renterghem, T., 2021. Predicting Outdoor Sound. CRC Press.
- Badino, A., Borelli, D., Gaggero, T., Rizzuto, E., Schenone, C., 2012a. Acoustic impact of ships: noise-related needs, quantification and justification. Proceedings of the 14th International Congress of the International Maritime Association of the Mediterranean, IMAM 2011 2, 961–969.
- Badino, A., Borelli, D., Gaggero, T., Rizzuto, E., Schenone, C., 2012b. Modelling the outdoor noise propagation for different ship types. In: NAV 2012 17th International Conference on Ships and Shipping Research.
- Badino, A., Borelli, D., Gaggero, T., Rizzuto, E., Schenone, C., 2016. Airborne noise emissions from ships: experimental characterization of the source and propagation over land. Appl. Acoust. 104, 158–171. <https://doi.org/10.1016/j.apacoust.2015.11.005>.
- Bernardini, M., Fredianelli, L., Fidecaro, F., Gagliardi, P., Nastasi, M., Licitra, G., 2019. Noise assessment of small vessels for action planning in canal cities. Environments 6 (3), 31. <https://doi.org/10.3390/environments6030031>.
- Borelli, D., Gaggero, T., Rizzuto, E., Schenone, C., 2016. Holistic control of ship noise emissions. Noise Mapp. 3 (1), 107–119.
- Brittain, F., 2004. Noise modeling using ISO 9613-2 for designing facilities to meet a not-to-exceed community noise limit. In: Noise-Con 04. The 2004 National Conference on Noise Control Engineering. Institute of Noise Control Engineering. Transportation Research Board.
- Brittain, F., 2009. Modeling community noise from power plants using ray-tracing software". In: Proc. Inter-noise 2009. Noise Control Foundation, Poughkeepsie, New York, Ottawa, Canada, 2009.
- Brittain, F.H., Hale, M.E., 2008. Some limitations of ray-tracing software for predicting community noise from industrial facilities. INTER-NOISE and NOISE-CON Congress and Conference Proceedings 2008 (1), 1303–1314. Institute of Noise Control Engineering.
- CONCAWE, 1981. "The Propagation of Noise from Petroleum and Petrochemical Complexes to Neighboring Communities," CONCAWE Report No. 4/81. Den Haag, 1981.
- Coppola, T., Mocerino, L., Rizzuto, E., Viscardi, M., Siano, D., 2018. Airborne noise prediction of a Ro/Ro pax ferry in the port of Naples. Technology and science for the ships of the future: proceedings of NAV 157.
- Coppola, T., Lorenzo, F.D., Mocerino, L., 2019. The irradiated noise underwater by the ships: a state of the art. In: Nautical and Maritime Culture, from the Past to the Future: Proceedings of the 3rd International Conference on Nautical and Maritime Culture, vol. 3. IOS Press, p. 90.
- Curcuruto, S., Marsico, G., Atzori, D., Mazzocchi, E., Betti, R., Fabozzi, T., et al., 2015. Environmental impact of noise sources in port areas: a case study. Proceedings of ICSV22, 12–16.
- de Lorenzo, F., Biot, M., Moro, L., 2010. Cruise SHIP noise pollution in harbour: suggestions for a design procedure. In: SHIP and ENGINE WORKSHOP: Vibration and Noise Targets for the Future.
- Di Bella, A., Remigi, F., 2013. Prediction of noise of moored ships. Proceedings of Meetings on Acoustics 19, 010053. <https://doi.org/10.1121/1.4799451>.
- Di Bella, A., Tombolato, A., Cordezzu, S., Zanutto, E., Barbieri, M., 2008. In situ characterization and noise mapping of ships moored in the Port of Venice, 2008. In: Proceedings of the 7th European Conference on Noise Control 2008. EURONOISE 2008, pp. 1949–1953.
- Directive, E.U., 2002. Directive 2002/49/EC of the European parliament and the Council of 25 June 2002 relating to the assessment and management of environmental noise. Off. J. Eur. Communities L 189, 2002, 2002.
- DNV QUIET, 2019. DNVGL GC313 Measurement Procedures for Noise Emission.
- Economou, P., Peppin, R.J., 2012. A comparison of iso 9613-2 and advanced calculation methods: predictions versus experimental results. Can. Acoust. 40 (3), 54–55.
- EcoPort Project, 2011. Information Exchange and Impact Assessment for Enhanced Environmental-Conscious Operations in European Ports and Terminals. FP5. Available online: http://cordis.europa.eu/project/rcn/87079_en.html. (Accessed 21 April 2023).
- EcoPort Project, 2020. EU Co-financed project through the European regional development fund (ERDF) in the framework of the adriatic new neighbourhood program INTER-REG/CARDS-PHARE 2000–2006. Available online: <https://www.port.venice.it/it/progetto-eco-port.html>. (Accessed 1 July 2020).
- ESI project. Available online: <https://www.environmentalshipindex.org/info->. (Accessed 21 April 2023).
- Fredianelli, L., Nastasi, M., Bernardini, M., Fidecaro, F., Licitra, G., 2020. Pass-by characterization of noise emitted by different categories of seagoing ships in ports. Sustainability 12 (5), 1740. <https://doi.org/10.3390/su12051740>.
- Herramienta Automática de Diagnóstico Ambiental, 2005. Automatic Tool for Environmental Diagnosis). LIFE02 ENV/E/000274; Environment-LIFE, Brussels, Belgium, 2005.
- IEC 61672-1. Electroacoustics - sound level meters - Part 1: specifications. <https://webstore.iec.ch/publication/5708>.
- IMO, 2001. International Convention on the Control of Harmful Anti-fouling Systems on Ships. [https://www.imo.org/en/About/Conventions/Pages/International-Convention-on-the-Control-of-Harmful-Anti-fouling-Systems-on-Ships-\(AFS\).aspx](https://www.imo.org/en/About/Conventions/Pages/International-Convention-on-the-Control-of-Harmful-Anti-fouling-Systems-on-Ships-(AFS).aspx).
- IMO, 2004. Implementing the Ballast Water Management Convention. <https://www.imo.org/en/MediaCentre/HotTopics/Pages/Implementing-the-BWM-Convention.aspx>.
- IMO, 2009. The Hong Kong International Convention for the Safe and Environmentally Sound Recycling of Ships. <https://www.imo.org/en/About/Conventions/Pages/The-Hong-Kong-International-Convention-for-the-Safe-and-Environmentally-Sound-Recycling-of-Ships.aspx>.
- IMO, 2014. MEPC.1/Circ.833 GUIDELINES for the REDUCTION of UNDERWATER NOISE from COMMERCIAL SHIPPING to ADDRESS ADVERSE IMPACTS on MARINE LIFE.
- ISO 3744, 2010. Acoustics — Determination of Sound Power Levels and Sound Energy Levels of Noise Sources Using Sound Pressure — Engineering Methods for an Essentially Free Field over a Reflecting Plane.
- ISO 8927, 1991. Earth-moving Machinery — Machine Availability — Vocabulary.
- ISO 9613-1, 1993. Acoustics – attenuation of sound during propagation outdoors - Part 1: calculation of the absorption of sound by the atmosphere. International Standard ISO 9613-1:1993.
- ISO 9613-2, 1996. Acoustics - attenuation of sound during propagation outdoors - Part 2: general method of calculation. International Standard ISO 9613-2:1996.
- ISO 9614-3, 2002. Acoustics — Determination of Sound Power Levels of Noise Sources Using Sound Intensity — Part 3: Precision Method for Measurement by Scanning.
- ISO/TR 17534-3, 2015. Acoustics — Software for the Calculation of Sound Outdoors — Part 3: Recommendations for Quality Assured Implementation of ISO 9613-2 in Software According to ISO 17534-1.
- Keller, J.B., 1962. Geometrical theory of diffraction. Josa 52 (2), 116–130.
- Lam, Y.W., 2005. Issues for computer modelling of room acoustics in non-concert hall settings. Acoust. Sci. Technol. 26 (2), 145–155. <https://doi.org/10.1250/ast.26.145>.
- Mocerino, L., Cascetta, F., Carteni, A., d'Accadia, M.D., Gallo, D., Quaranta, F., 2022. The evaluation of the impact on the quality of the atmosphere of all activities carried out in the ports of Naples and Salerno. Case Studies in Chemical and Environmental Engineering 6, 100263. <https://doi.org/10.1016/j.csee.2022.100263>.
- Neptunes project. Available online: <https://neptuneproject.eu/>. (Accessed 21 April 2023).
- NoMEPorts, 2008. Noise Management in European Ports, LIFE05 ENV/NL/000018, Good Practice Guide on Port Area Noise Mapping and Management. Technical Annex; Environment-LIFE, Brussels, Belgium, 2008.
- Nord2000, Kragh, J., Plovsing, B., Storeheier, S., Jonasson, H., 2002. Nordic Environmental Noise Prediction Methods, Nord2000, Summary Report, General Nordic Sound Propagation Model and Applications in Source-Related Prediction Methods, DELTA for Nordic Noise Group. Report AV 1719/01 (December 2001, Revised May 2002).
- Nota, R., Barelds, R., van Maercke, D., 2005. Harmonoise WP 3 Engineering Method for Road Traffic and Railway Noise after Validation and Fine-Tuning. Deliverable of WP3 of the HARMONOISE Project. Document ID HAR32TR-040922-DGMR20. Technical Report HAR32TR-040922-DGMR20.
- Pemard, P. E. Mediterranean Acoustics Research & Development Ltd. (PEMARD), "Olive Tree Lab – Terrain" (OTL Terrain).
- Register, Lloyd's, 2019. Design and Construction Additional Design and Construction, Procedure for the Determination of Airborne Noise Emissions from Marine Vessels. Lloyd's Register Group Limited, 2019 Published by Lloyd's Register Group Limited.

- RINA, 2021. Rules for the Classification of Ships Part F Additional Class Notations. Genoa, Jul. 2021. (Accessed 17 December 2021).
- Schenone, C., Pittaluga, L., Borelli, D., Kamali, W., El Moghrabi, Y., 2016. The impact of environmental noise generated from ports: outcome of MESP project. *Noise Mapp.* 3 (1) <https://doi.org/10.1515/noise-2016-0002>.
- Schiavoni, S., D'Alessandro, F., Borelli, D., Fredianelli, L., Gaggero, T., Schenone, C., Baldinelli, G., 2022. Airborne sound power levels and spectra of noise sources in port areas. *Int. J. Environ. Res. Publ. Health* 19 (17), 10996. <https://doi.org/10.3390/ijerph191710996>.
- SILENV, 2012. Ships oriented innovative solutions to rEduce noise and vibrations, FP7. Available online: <https://cordis.europa.eu/project/id/234182/reporting/it>. (Accessed 21 April 2023).
- SIMPYC, 2008. Sistema de Integración Medioambiental de Puertos y Ciudades (Environmental integration for ports and cities), LIFE04 ENV/ES/000216. Environment-LIFE, Brussels, Belgium, 2008.
- United Nations, 2019. Review of Maritime Transport-2019. United Nations Conf. Trade Develop, New York, NY, USA, 2019. https://unctad.org/system/files/official-document/rmt2019_en.pdf. (Accessed 21 April 2023).
- VDI, 1988. VDI 2714: Outdoor Sound Propagation. Beuth Verlag, Berlin, p. 18, 1988.
- Vukić, L., Peronja, I., Glavinović, R., 2022. Multi-faceted analysis of airborne noise impact in the port of split (I). *J. Mar. Sci. Eng.* 10 (10), 1564. <https://doi.org/10.3390/jmse10101564>.
- Weyna, S., 2021. Silent ships-a new challenge for the shipbuilding industry. *Am. J. Mod. Phys.* 10 (4), 71–92. <https://doi.org/10.11648/j.ajmp.20211004.12>.