

# IMPLEMENTATION OF A SENSORIZED NEONATAL HEAD MODEL FOR GYNECOLOGICAL TRAINING

S. Ricci<sup>(a)</sup>, S. Marcutti<sup>(b)</sup>, A. Pani<sup>(c)</sup>, M. Chirico<sup>(d)</sup>, G. Torre<sup>(e)</sup>, M. Cordone<sup>(f)</sup>, M. Casadio<sup>(g)</sup>, G. Vercelli<sup>(h)</sup>

<sup>(a),(b),(c),(g),(h)</sup> Department of Informatics, Bioengineering, Robotics and System Engineering, University of Genova, Italy  
<sup>(d),(e),(f)</sup> Centro di servizio di Ateneo di simulazione e formazione avanzata, University of Genoa, Italy

<sup>(a)</sup> [serena.ricci@edu.unige.it](mailto:serena.ricci@edu.unige.it), <sup>(b)</sup> [simone.marcutti@edu.unige.it](mailto:simone.marcutti@edu.unige.it), <sup>(c)</sup> [andre-p23@hotmail.it](mailto:andre-p23@hotmail.it), <sup>(d)</sup> [marco.chirico@unige.it](mailto:marco.chirico@unige.it),  
<sup>(e)</sup> [gctorre@unige.it](mailto:gctorre@unige.it), <sup>(f)</sup> [massimo.cordone@gaslini.org](mailto:massimo.cordone@gaslini.org), <sup>(g)</sup> [maura.casadio@unige.it](mailto:maura.casadio@unige.it), <sup>(h)</sup> [gianni.vercelli@unige.it](mailto:gianni.vercelli@unige.it)

## ABSTRACT

During labor it is very important to know the exact position and orientation of the fetal head when descending the birth canal. Indeed, incorrect evaluations may lead to dangerous situations for both the infant and the mother. Usually, gynecologists and midwives rely on their experience to determine the head position and to evaluate the risk level of each delivery. In this context, it is essential to train new physicians and midwives to correctly manage different types of delivery.

Here, we present the design and implementation of a realistic sensorized neonatal head that could be used on low-cost birth simulators for training and evaluation of residents and midwifery students.

Keywords: medical simulation, delivery, 3D modeling, 3D printing

## 1. INTRODUCTION

Residents and students estimate the hazard of a labor by looking at the position of the fetus in the birth canal. Emergency cases are treated with instruments such as the forceps and ventouse or through cesarean section. In order to define the fetal position, physicians take advantage of anatomical landmarks in the maternal pelvis and fetal head. In this way, they can establish whether the head of the fetus can descent in the birth canal without any risk. Specifically, they consider the maternal ischial spines and the fontanels in the fetal head (Cunningham et al. 2010). The former determine the interspinous diameter that is the narrowest space of the birth canal; the latter are membranous spaces linking different bones in the head; the anterior fontanel has a lozenge shape, while the posterior is triangular and smaller, compared to the anterior one (Cunningham et al. 2010). Briefly, the labor can be divided in three phases: the first starts when regular contractions occur and ends once the cervix is 10 cm dilated; the second ends after the baby is born; the last phase includes the delivery of the placenta. During the second stage, the baby undergoes strong pressures, i.e. uterine contractions, to descent in the birth canal. In order to cross the interspinous diameter, the head needs to be in the correct position (Cunningham et al. 2010).

Physicians and midwives mainly rely on their previous knowledge and experience to determine the fetal head position. Therefore, it is critical to train student to build a solid background based on evidence (Rubin and Coopland 1970).

Currently, residents can practice only in routine deliveries; however, when they start their practice it is important for them to be able to identify and treat also unusual and risky situations.

In this context, simulation in medicine can be the right tool for the training of doctors and paramedics. Actually, different type of clinical cases can be simulated, and users can learn how to react in specific scenarios (Macedonia, Gherman, and Satin 2003). In order for the simulation to be useful, it is important that the right level of realism is reached (Christou 2010; Witmer and Singer 1998). This would enhance the emotional and psychological involvement, resulting in an optimization of the learning process (Christou 2010; Witmer and Singer 1998). Medical simulators can be divided into three categories (Bradley 2006):

- part-task trainers, i.e. simple body districts lacking any advanced technology, which are used to learn simple tasks such as: intramuscular injections;
- computer-based system used to train decision making through serious games, virtual reality, haptic systems
- integrated simulators: full-body mannequins equipped with sensors and used for multidisciplinary training, i.e. first aid procedures

Each class has positive aspects which can enhance the learning process of students (Stabilini et al. 2013); to this extent, a combination of technologies may be suitable to make medical simulation more efficient. Currently, several commercial products exist. Among the others, it is worth mentioning Noelle (Gaumard Scientific, USA), SimMom (Laerdal, Norway), and SIMone (3b Scientific, Germany). The first two tools are integrated simulators, while SIMone combines a part-task trainer model with hardware and software components. Additionally, some research groups

worked on prototypes of birth simulators aimed at training residents who need to perform pelvic examinations and forceps extractions (Pugh and Youngblood 2002; Dupuis et al. 2006). Despite the fact that they are all useful tools, their high cost and size make them not fully accessible by end users. In this context, we combined low-cost hardware and software to develop a birth simulator which is a fusion of low-cost hardware and software. Specifically, we focused on the fetal head which is the core of our simulator.

## 2. OBJECTIVE

Recently, our group has developed eBSim, a birth simulator which combines features of part-task trainers, computer-based systems and integrated simulators (Ricci et al. 2015; Paci et al. 2016; Ricci et al. 2019). eBSim incorporates a physical model of the maternal pelvis and fetal head, with a corresponding virtual representation. Specifically, the simulator measures the position, i.e. the orientation of the head with respect to the ischial spines; the level of descent of the infant in the birth canal (station); the touch of the two main fontanels in the fetal head. Physical and virtual models communicate in real time thanks to sensors located in the fetal head and pelvis, so that a movement in the mannequin corresponds to the same movement in its virtual representation. eBSim was designed to be an educational tool for the training and evaluation of students in gynecology and obstetrics. The goal of the project was to realize the proof of concept of a low-cost simulator, which was also portable and plug and play. Moreover, we decided to assess the potentialities of low-cost open source hardware and software. After the realization of the first prototype, we were able to define the major criticisms of the project, defining corrective actions to improve usability of eBSim.

One of the most important features of birth simulators is the fetal head, which has to be realistic in its anatomical markers so that doctors can learn how to take advantage of them during labors. The first prototype we developed included a 3D model of the fetal head which was divided in two hemispheres and 3D printed in ABS material (Acrylonitrile butadiene styrene). This model was difficult to use for efficient training because the material was too rigid to resemble a fetal skin and the precision of the 3D model was far from being a high-fidelity fetal head. Additionally, the model contained slots for sensors which were not optimized. For all these reasons, this project focuses on the realization of a high-fidelity fetal head usable on eBSim. The result is a multi-layers 3D model of the fetal head containing the majority of eBSim's hardware and designed so that the main anatomical landmarks, i.e. sutures and fontanels are clearly detectable on the head's surface.

## 3. SOLUTION

The implementation of the head can be divided in three phases:

- Hardware advancement
- 3D modelling
- 3D printing

### 3.1. Hardware advancement

As described below, eBSim determines position and station of the mannequin inside a simulated birth canal; additionally, it detects the user touch of the two fontanels. To do so we selected two types of sensors, preferring devices which were both low-cost and small. Specifically, we chose:

- Inertial Measurement Unit (IMU, InvenSense MPU-6050) to define the position of the head (orientation with respect to the maternal ischial spines);
- Two force sensors (Force Sensing Resistors 0.6") to distinguish the touch of the fontanels;

The IMU is an integrated chip embedding a 3-axis MEMS (Micro Electro-Mechanical Systems) accelerometer and gyroscope converting mechanical oscillations into numerical values through three 16-bit ADC (Analog-to-Digital Converter), one for each x, y, z, direction. Such values represent movements with respect to the reference system, which depends on the initial position of the sensor. A Digital Motion Processor (DMP) combines accelerations and rotations from the three directions into a quaternion. Quaternions were sent in real time via Bluetooth (BLE) to the software (described below) to replicate the head position in the virtual representation. IMU, two force sensors and the Bluetooth modules are located inside the fetal head and connected to an Arduino Uno<sup>®</sup> Board (Figure 1).

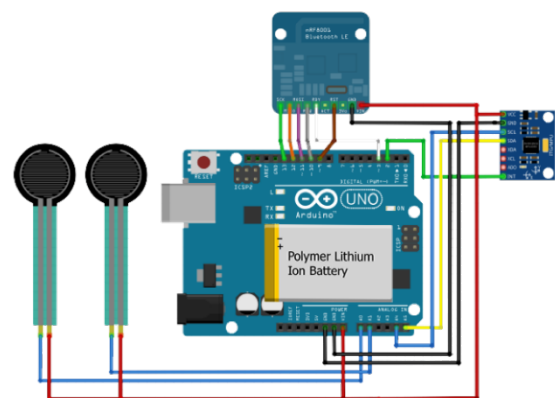

Figure 1. Schematic of the Arduino Uno board. Two force sensors (on the left), a Bluetooth module (top) and an IMU (right). The whole system is powered by a lithium battery.

### 3.2. 3D Modelling

The first version of the simulator provided a 3D model of the fetal head divided in two hemispheres, which also included slots for all the hardware (Figure 2). However, such model lacked in interlocks and needed an optimization of both the computational complexity and slot locations. Thus, we decided to print the head in two separated layers with different thicknesses and materials. The internal layer needed to be rigid in order to resemble the skull and to enclose and protect the hardware. The external one, instead had to be soft and detailed to mimic the fetal skin covering sutures and fontanels.

The design and the development of the 3D model followed a two stages workflow. In the first stage, we used a free model of a baby head in order to test the idea and the concept. After the first successful test, in which we tried the synchrony between the physical model and its virtual representation, we decided to improve our model and its features reproducing a more accurate and detailed 3D version of the fetal head. We thus acquired the geometry of a mannequin representing a realistic baby. Firstly, we imported the model into 3DS Max® (Autodesk, USA), to separate the head from the body and we applied retopology, a process useful for decreasing the level of the definition without losing quality or detail. Briefly, starting from the first version, we built an identical model with less polygons to make it easily usable in the game engine. Since we had to print two layers, we decided to create a 3D model with no thickness. In this way, it was possible to add thickness in one of the two sides of the interface and thus design the internal or external layer.

The internal layer also required a reorganization of the hardware slots and the addition of an interlock mechanism. Hence, we firstly added a 3 mm thickness to the model to make it rigid enough to contain all the hardware, and with a realistic weight. We decided to locate all the sensors in the left hemisphere and to use the right one as a cover. In detail, the Arduino Uno slot is vertical and merged together with the IMU and Bluetooth slots (Figure 3). Additionally, the internal layer has two openings on its surface, in correspondence of the two fontanels, containing the force sensors. Finally, we added four lock-blocks to the system to join the two hemispheres (Figure 4A).

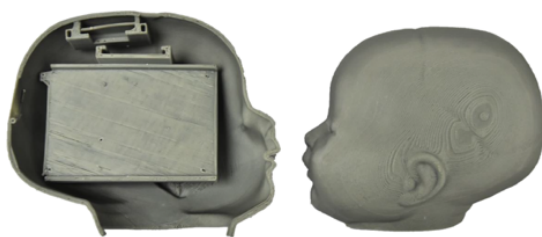

Figure 2. First model of the fetal head printed in ABS material. The right hemisphere contained slots for Arduino, IMU and Bluetooth modules.

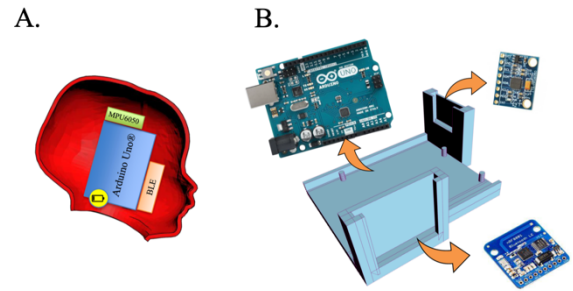

Figure 3. A. Schematic of the right hemisphere of the fetal head. B. 3D model of the hardware slots.

The external layer had been realized following the same steps of the internal one, with the exception of the hardware slots and lock-blocks. The differences of this model with respect to the internal one concern mainly the thickness and the precision of the head. Specifically, the thickness of this layer was lower than 3 mm and it was added from the external side of the interface; also, we increased the number of polygons of this level making it more precise and high-fidelity than the internal layer (Figure 4B). Finally, the two hemispheres were merged together, and this model was imported in Unity platform, to create the virtual scene of the delivery.

### 3.3. 3D printing

The internal layer was printed in ABS using Makerbot™ Replicator 2X (Makerbot, USA), a Fused Deposition Modeling printer. This material was selected because it is a low-cost polymer which is also resistant with a low weight. The external layer, instead, was printed using SLA (stereolithography) printer (Form2, Formlabs, USA). SLA allows for high resolution printing. Specifically, we used a Flexible Resin (Formlabs, USA), designed for the simulation of soft touch-materials and multi-materials models (<http://www.formlabs.com/>). After the printing, the two layers were assembled together. Particularly, the two internal hemispheres were joint through the four lock-blocks, while the external layer, having elastic characteristics, adhered to the internal one (Figure 5).

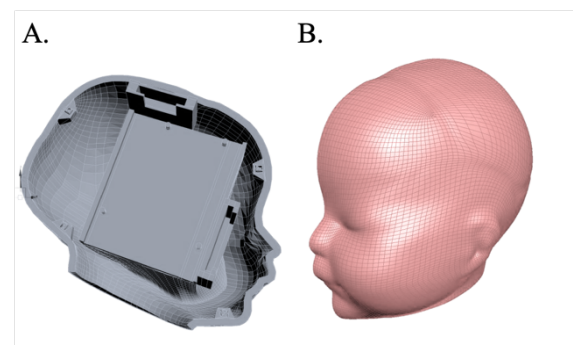

Figure 4. A. 3D model of the internal layer of the fetal head. B. external layer, right hemisphere



Figure 5. 3D printing of the fetal head

### 3.4 Usage

The final version of the head was used for real-time data acquisition of the position and orientation data, as well as for the detection of fontanel touch. Information from the head was sent to a server which shared such data through two different protocols (BLE, websocket) with the clients connected (i.e. desktops, laptops, tablets). In this way, it was possible to replicate the physical behavior inside a virtual representation, in order to give visual feedback to the users.

With such system, the students can have a feedback on what they are doing and thus building skills that they will reuse during their professional career. eBSim was developed with the aim to give students two possibilities: training mode and simulation mode. The former, allows them to learn skills through the virtual representation, the latter instead can be used as a self-evaluable tool which does not allow for the visual feedback. Furthermore, we implemented an exam mode that instructor can use to objectively tests students (Ricci et al. 2019).

## 4. CONCLUSIONS AND FUTURE DEVELOPMENT

The goal of the project was to redesign a model of a fetal head, which is a part of eBSim, a low-cost birth simulator for the training and evaluation of gynecologists and obstetricians. Starting from the first prototype, we worked on the 3D head model, optimizing hardware and software. Even though the model has improved considerably compared to the first prototype, a few points still need to be addressed to make the head fully usable by learners and instructors. In detail, the IMU sensor presented some malfunctions in the initialization and determination of the rotation angles. This issue should be deeper investigated, and alternative sensors might be tested, and compared to the current device. Also, the 3D model could be further improved: currently, the head is divided in two symmetric hemispheres; however, such division might be perceived by the user who could take advantage of an improper marker. For this reason, different partitions of the model should be tested; an idea might be to divide each hemisphere in three parts, following the head's sutures or to print the top layer without the

hemisphere division so that it wraps the internal layer. Likewise, the interlocks system could be advanced, designing a joint system covering the whole head instead of simple lock blocks. Another important development would be to create a full-body mannequin, rather than the single head. This would make eBSim usable also for the simulation of both natural and breech deliveries, drastically improving its value as an educational tool. Finally, the way we designed our tool gives us the opportunity to be modular and flexible; this means that it would be possible to integrate new components and eventually make the fetal head usable with existing simulators. In particular, the use different protocols of communication and hardware components can address the interoperability issue with external systems or platforms.

### ACKNOWLEDGMENTS

This work was partially supported by Ministry of Science and Technology, Israel (Joint Israel-Italy Lab in Biorobotics Artificial Somatosensation for Humans and Humanoids). Serena Ricci and Simone Marcutti equally contributed to this work. We thank: E. Bellanti, G. Carlini and P. Marchiolè for their help in the initial stage of the work.

### REFERENCES

- Bradley, Paul. 2006. "The History of Simulation in Medical Education and Possible Future Directions." *Medical Education* 40 (3): 254–62.
- Christou, Chris. 2010. "Virtual Reality in Education." In *Affective, Interactive and Cognitive Methods for e-Learning Design: Creating an Optimal Education Experience*, 228–43. IGI Global.
- Cunningham, F Gary, J Kenneth Leveno, L Steven Bloom, C John Hauth, J Dwight Rouse, and Y Catherine Spong. 2010. "Williams Obstetrics 23rd Edition McGraw Hill." *New York*, 2010.
- Dupuis, Olivier, Richard Moreau, Ruimark Silveira, Minh Tu Pham, Adrien Zentner, Michel Cucherat, Rene-Charles Rudigoz, and Tanneguy Redarce. 2006. "A New Obstetric Forceps for the Training of Junior Doctors: A Comparison of the Spatial Dispersion of Forceps Blade Trajectories between Junior and Senior Obstetricians." *American Journal of Obstetrics and Gynecology* 194 (6): 1524–31. <https://doi.org/10.1016/j.ajog.2006.01.013>.
- Macedonia, Christian R, Robert B Gherman, and Andrew J Satin. 2003. "Simulation Laboratories for Training in Obstetrics and Gynecology." *Obstetrics & Gynecology* 102 (2): 388–92.
- Paci, Andrea, Simone Marcutti, Serena Ricci, Maura Casadio, Gianni Viardo Vercelli, Pierangelo Marchiolè, and Massimo Cordone. 2016. "EBSim: Development of a Low-Cost Obstetric Simulator." In *International Conference on Augmented Reality, Virtual Reality and Computer Graphics*, 101–10. Springer.



- Pugh, Carla M, and Patricia Youngblood. 2002. "Development and Validation of Assessment Measures for a Newly Developed Physical Examination Simulator." *Journal of the American Medical Informatics Association* 9 (5): 448–60.
- Ricci, Serena, Simone Marcutti, Andrea Pani, Massimo Cordone, Giancarlo Torre, Gianni Viardo Vercelli, and Maura Casadio. 2019. "Design and Implementation of a Low-Cost Birth Simulator." In *41st Engineering in Medicine and Biology Conference*.
- Ricci, Serena, Andrea Paci, Simone Marcutti, Pierangelo Marchiolè, Giancarlo Torre, Maura Casadio, Gianni Viardo Vercelli, and Massimo Cordone. 2015. "The Development of a Low-Cost Obstetric Simulator to Train Midwifery Students and Test Objective Examinations' Skills." In *4th International Workshop on Innovative Simulation For Healthcare*.
- Rubin, Leon, and Ashely Coopland. 1970. "Kielland's Forceps." *Canadian Medical Association Journal* 103 (5): 505.
- Stabilini, Cesare, Umberto Bracale, Giusto Pignata, Marco Frascio, Marco Casaccia, Paolo Pelosi, Alessio Signori, et al. 2013. "Laparoscopic Bridging vs. Anatomic Open Reconstruction for Midline Abdominal Hernia Mesh Repair [LABOR]: Single-Blinded, Multicenter, Randomized, Controlled Trial on Long-Term Functional Results." *Trials* 14 (October): 357. <https://doi.org/10.1186/1745-6215-14-357>.
- Witmer, Bob G, and Michael J Singer. 1998. "Measuring Presence in Virtual Environments: A Presence Questionnaire." *Presence* 7 (3): 225–40.

#### AUTHORS BIOGRAPHY

**S. Ricci** is a PhD student in Bioengineering and Robotics at the University of Genoa (UNIGE), Italy in collaboration with the New York City College, USA. Her research interests are medical simulation and EEG data analysis.

**S. Marcutti** is a PhD student in Digital Humanities of UNIGE. He has a master's in Communication Theory and Technology at the University of Milan Bicocca, Italy. His research interests are interaction design, natural user interfaces, internet of things, augmented, mixed and virtual reality.

**A. Pani** has a master's in Bioengineering from UNIGE.

**M. Chirico** is the CEO of the Simulation and advanced education center (SIMAV) Genoa. He was engineer at the same university, and CIO of the National Cancer Institute, Genoa. He has a master's in electronic engineering. His research interests include e-health, simulated healthcare systems, simulation-based medical education.

**G. Torre** is the honorary president of SIMAV. He is a surgeon and was head of School of Medicine, UNIGE and head of the Surgeon Department of S. Martino Hospital, Genova.

**M. Cordone** is obstetrician, gynecologist and surgeon, head of the Labor & Delivery Unit of Gaslini Institute, Genoa. He is also professor of Clinical Simulation UNIGE.

**M. Casadio** is Associate Professor of Biomedical Engineering of UNIGE. She has a PhD in Bioengineering, master's degrees in Electronic and Biomedical Engineering. She worked at the Don Gnocchi Foundation, La Spezia, Italy and she was a post-doctoral fellow at Northwestern University, USA. Her research interests are neural control of movements, assistive and rehabilitation robotics, body machine interfaces.

**G. Vercelli** is Associate Professor of UNIGE, school of Engineering. He received a master's degree in Electronic Engineering and a PhD in Informatics Engineering. He worked at the University of Trieste, Italy and founded TAU software house. His research interests include robotics, eLearning, medical simulation, drones and augmented reality.